

Pump Pompa	Pressure Pressione		Volume Portata				RPM giri/min		Power Potenza			
			l/min		GPM				HP		kW	
	bar	PSI	50 Hz	60 Hz	50 Hz	60 Hz	50 Hz	60 Hz	50 Hz	60 Hz	50 Hz	60 Hz
GXT6028S	280	4060	60	72	15,7	18,8	1000	1200	43,0	51,6	31,7	38,0
GXT8020S	200	2900	80	96	20,9	25,1	1000	1200	41,1	49,3	30,2	36,2
GXT1020S	200	2900	100	120	25,8	31	1000	1200	51,3	64,6	37,7	45,4
GXT1215S	150	2175	120	144	31,3	37,6	1000	1200	47,0	56,4	34,6	41,5
GXT1515S	150	2175	150	180	39,2	47,0	1000	1200	59,0	70,8	43,4	52,1
GXT1712S	120	1740	170	204	45,0	54,0	1000	1200	52,4	62,9	38,6	46,3

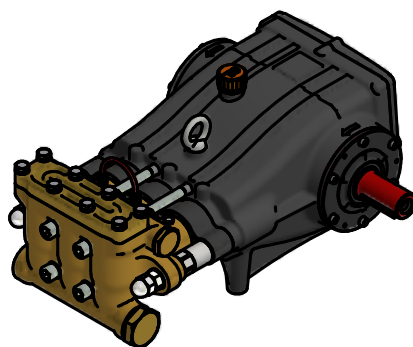

Dimensioni d'ingombro

Overall dimensions

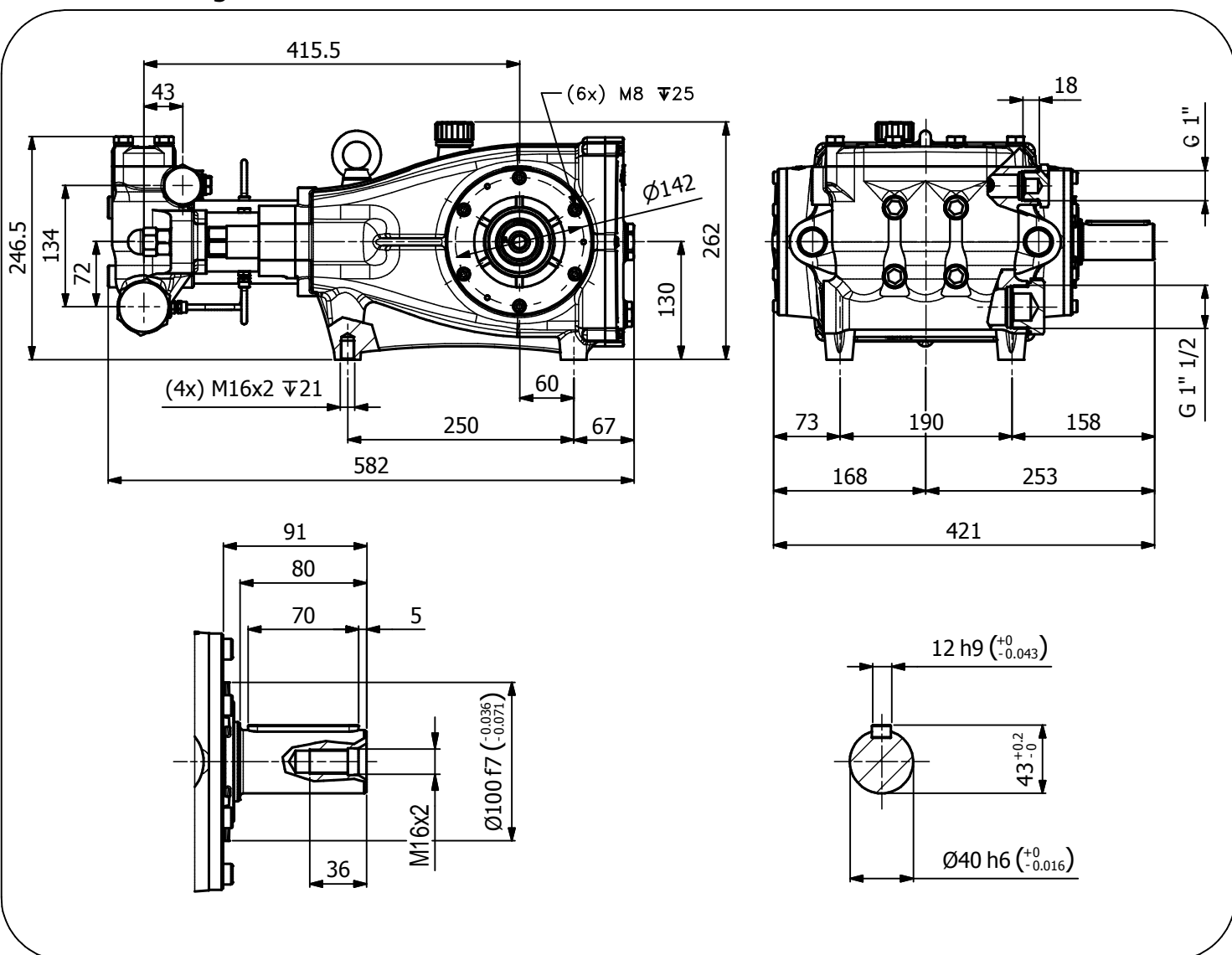

Lubrificazione: Olio SAE 10W-40
 Capacità: 5,5 Litri
 Peso pompa: 67,5 Kg

Lubrication: SAE 10W-40 Oil
 Capacity: 5,5 Litres
 Weight: 67,5 Kg

